

# Determination of sugar inversion rate constant by polarimetric measurement

Theoretical background: P.W. Atkins: *Physical Chemistry*.

Type of practice: Individual.

Purpose of practice: To investigate the decomposition of sucrose under pseudo-first-order conditions and to study the operation of polarimeters in measuring optical activity.

## 1 Introduction

Sucrose or common sugar (cane sugar, beet sugar, maple sugar) is a disaccharide composed of glucose and fructose. It is produced by plants and is an important food for heterotrophic organisms. Edible sugar, known as granulated sugar, is made primarily from sugar beet or sugar cane.

The decomposition of sucrose ( $C_{12}H_{22}O_{11}$ ) to glucose (D-glucose) and fructose (D-fructose) in a neutral aqueous medium is a slow process (Fig. 1). The reaction is catalyzed by acids.

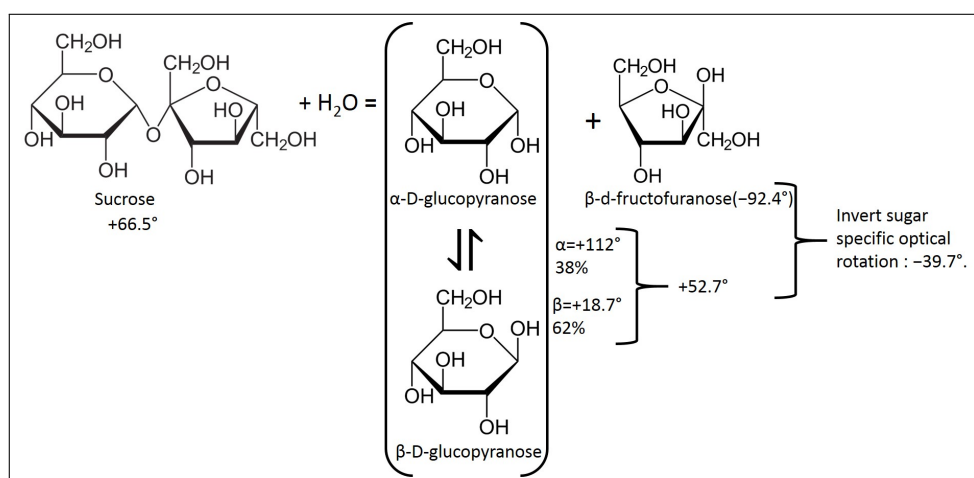

Figure 1: Decomposition of sucrose and specific rotations of the components at 589 nm.

In the reaction, each saccharide is optically active, i.e., it rotates the plane of polarization of light. Light, as an electromagnetic wave, involves propagating electric and magnetic field oscillating perpendicular to each other. The plane of oscillation of light emitted from a natural light source can be any. Some devices

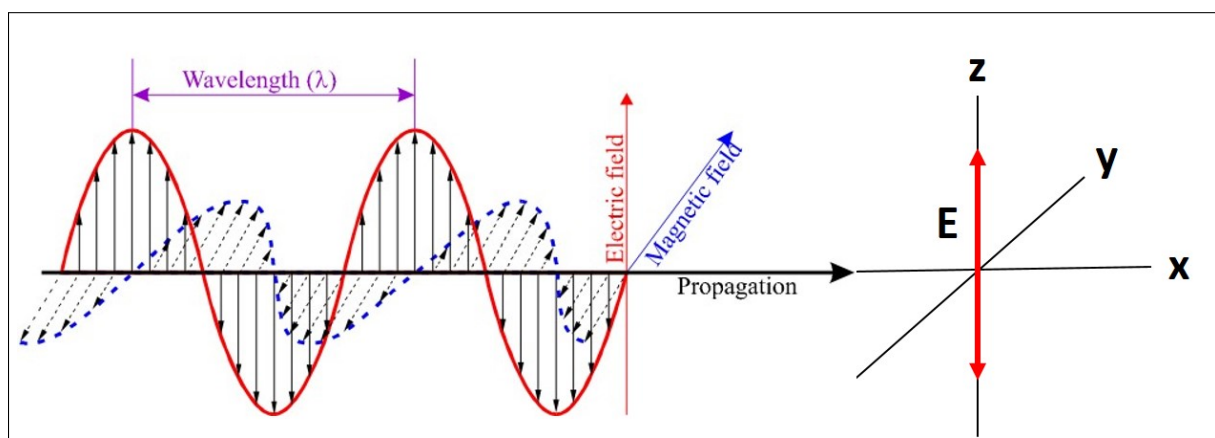

Figure 2: Sketch of a monochromatic electromagnetic wave polarized in a plane (linearly).

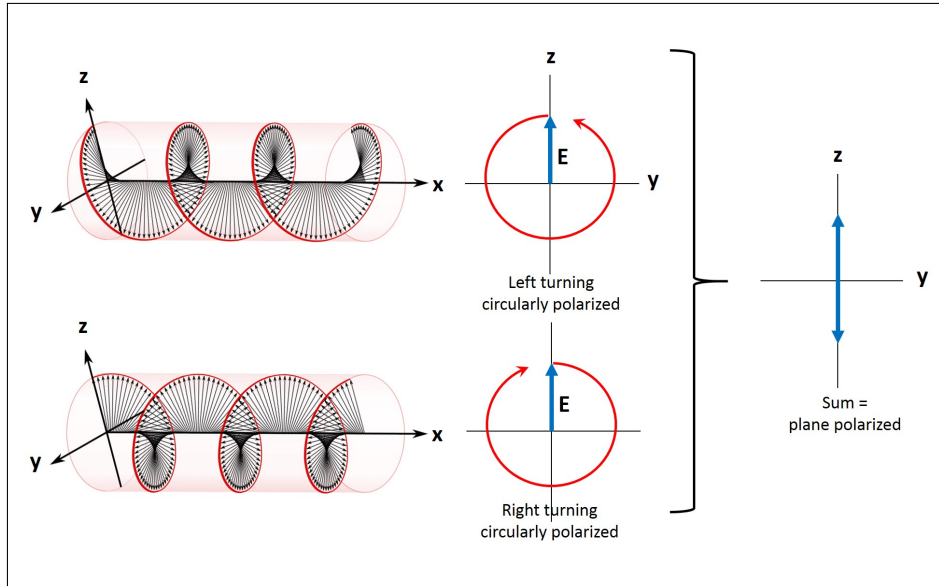

Figure 3: Plane-polarized light as the sum of two circularly polarized lights.

(so-called polarizers) select waves that oscillate in one plane, making the transmitted light plane-polarized (linearly polarized, Fig. 2). These can be birefringence prisms, or polaroid films, etc.

The interaction of polarized light with an optically active substance (asymmetric crystals or molecules) causes the plane of polarization to rotate (to the right or left), and this rotation can be detected by another polarizer (analyzer). To illustrate this, it is best to consider plane-polarized light as the sum of two circularly polarized lights (Fig. 3). Depending on the direction of rotation of the circular polarization, the interaction of the optically active substance (left-handed or right-handed, i.e., optical isomers) and light, the circularly polarized light rotating left and right, "detects" a medium with different refractive indices, so it passes through the medium with different speeds. Their sum will be a polarized light, but the plane of polarization will be rotated. This angle of rotation can be detected with another polarizer, the analyzer. The essence of the detection is that the analyzer transmits the most light when its optical axis is in the plane of polarization, and the least light when it is perpendicular to it. (See Fig. 4 and Fig. 5).

The optically active material changes this angle between the polarizer and the analyzer for the highest intensity or total extinction. Angle of rotation caused by the optically active material ( $\theta / ^\circ$ ) is proportional to the number of particles (concentration,  $c / M$ ) and to the optical path length ( $\ell / dm$ ), and depends on the temperature ( $T$ ) and the wavelength of light ( $\lambda$ ) is

$$\theta = c \cdot \ell \cdot [\Theta]_m^{(T, \lambda)}$$

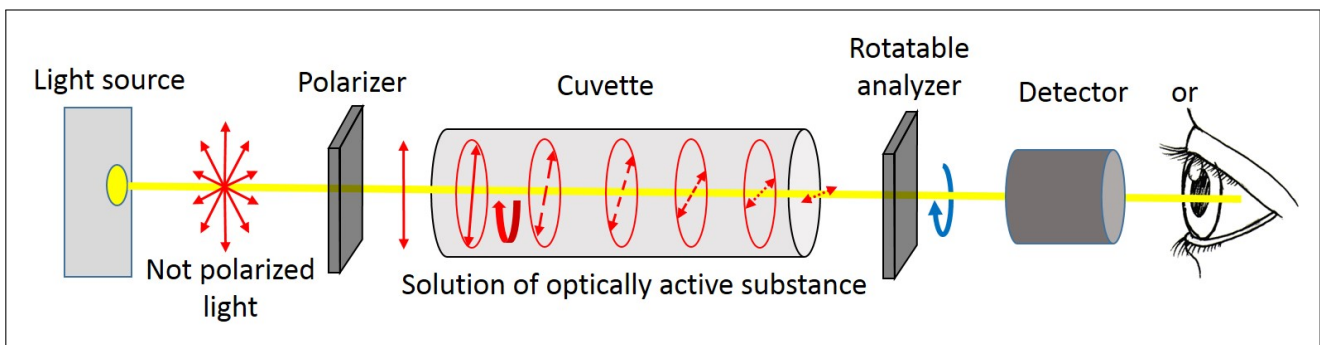

Figure 4: Detection of the angle of rotation of light, the theoretical structure of the polarimeter.

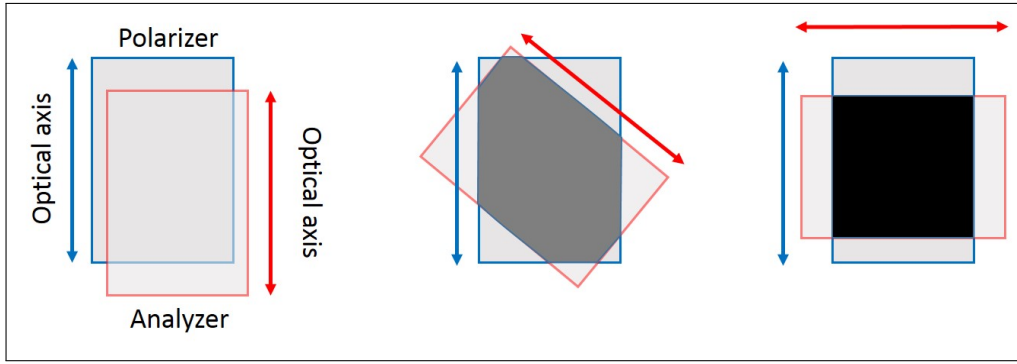

Figure 5: Polarizer and analyzer.

where the proportionality factor is the molar rotation ( $[\Theta]_m^{(T,\lambda)}$ ). When several types of optically active substances are present together, their total effect is a simple sum of the rotations, i.e.,

$$\theta = \sum_{i=1}^n c_i \cdot \ell \cdot [\Theta]_i^{(T,\lambda)}.$$

Often, instead of the molar concentration, we use the mass concentration (in  $\text{g/cm}^3$  units), the optical path length is expressed in dm, and thus, the so-called specific rotation is the proportionality factor. Its unit is  $(^\circ \text{cm}^3)/(\text{gdm})$ . In the case of various saccharides their values can be seen in Fig. 1. Specific rotation in the decomposition of sucrose changes from  $+66.5^\circ$  to  $-39.7^\circ$  (applying  $1 \text{ g/cm}^3$  solution composition and  $1 \text{ dm}$  light path) i.e., changes sign. Products rotate light in a different direction than the starting material that is why the reaction is called inversion.

During the reaction, the  $(\alpha)$ -D-,  $(\beta)$ -D-glucose equilibrium is reached very fast, practically all the way to their average value (D-glucose). The concentration of water is very high, so the amount changes negligibly by the hydrolysis, and the oxonium ion is recovered as a catalyst during the reaction, i.e., the change in the concentration of only one component has to be taken into account, the reaction is "apparently" first order, i.e., pseudo-first order reaction.

## 1.1 Evaluation of first-order kinetics by polarimetry

For a kinetically first-order process (e.g.,  $A \rightarrow \text{Product(s)}$  transformation) the differential form of the rate equation is

$$-\frac{d[A]}{dt} = k[A]$$

The integrated form is

$$[A] = [A]_0 e^{-kt}$$

where  $[A]$  is the actual, while  $[A]_0$  is the initial concentration,  $k$  is the rate coefficient and  $t$  the time. Initially, for the reaction under study ( $t = 0 \text{ s}$ ) there is only sucrose ( $s$ ) in the solution, so the initial rotation is

$$\theta_0 = [s]_0 \cdot \ell \cdot [\Theta]_s.$$

During the reaction, three components are present, sucrose ( $s$ ), glucose ( $g$ ), and fructose ( $f$ ), so

$$\theta_t = [s] \cdot \ell \cdot [\Theta]_s + [g] \cdot \ell \cdot [\Theta]_g + [f] \cdot \ell \cdot [\Theta]_f.$$

It follows from the stoichiometry that  $[g] = [f] = [s]_0 - [s]$ , so

$$\theta_t = [s] \cdot \ell \cdot [\Theta]_s + ([s]_0 - [s]) \cdot \ell \cdot [\Theta]_g + ([s]_0 - [s]) \cdot \ell \cdot [\Theta]_f.$$

After the reaction is completed, only glucose and fructose remains, and  $[g] = [f] = [s]_0$ , i.e.,

$$\theta_{\infty} = [s]_0 \cdot \ell \cdot [\Theta]_g + [s]_0 \cdot \ell \cdot [\Theta]_f,$$

so

$$\theta_0 - \theta_{\infty} = [s]_0 \cdot \ell \cdot ([\Theta]_s - [\Theta]_g - [\Theta]_f)$$

and

$$\theta_t - \theta_{\infty} = [s] \cdot \ell \cdot ([\Theta]_s - [\Theta]_g - [\Theta]_f),$$

i.e.,

$$\frac{[s]}{[s]_0} = \frac{\theta_t - \theta_{\infty}}{\theta_0 - \theta_{\infty}} = e^{-kt}. \quad (1)$$

It can be seen from the equations that the concentration ratios can be determined without knowing the optical path length and specific rotations, and thus the rate constant can be calculated. The methods for this are discussed below.

## 1.2 Evaluation methods

1. **Point-by-point evaluation:** According to the rearranged Eq.(1)

$$k = -\frac{1}{t} \ln \frac{\theta_t - \theta_{\infty}}{\theta_0 - \theta_{\infty}}$$

$k$  is calculated at each measurement point and the values are then averaged. This method requires rotations measured at the beginning and end of the reaction.

2. **Straight line fitting with one parameter:**

$$\ln \frac{\theta_t - \theta_{\infty}}{\theta_0 - \theta_{\infty}} = -k \cdot t$$

Plotting the values calculated from the experimental data as a function of time, we obtain a line through the origin, and from the slope the rate constant can be determined. This method also requires rotations measured at the beginning and end of the reaction.

3. **Straight line fitting with two parameters:**

$$\ln(\theta_t - \theta_{\infty}) = \ln(\theta_0 - \theta_{\infty}) - k \cdot t$$

Plotting the values calculated from the experimental data as a function of time, we obtain a straight line. From the slope, the rate constant, from the intercept  $\theta_0$  can be calculated. This method requires only the rotation measured at the end of the reaction.

4. **Straight line fitting using the Guggenheim method:** This method is proposed when determining  $\theta_{\infty}$  and  $\theta_0$  is difficult experimentally. At a given  $t_i$  time

$$(\theta_{t_i} - \theta_{\infty}) = (\theta_0 - \theta_{\infty}) \cdot e^{-kt_i}$$

and at  $t_{i+1} = t_i + \Delta t$  time:

$$(\theta_{t_{i+1}} - \theta_{\infty}) = (\theta_0 - \theta_{\infty}) \cdot e^{-k(t_i + \Delta t)}.$$

Taking the difference of the two equations:

$$(\theta_{t_i} - \theta_{t_{i+1}}) = (\theta_0 - \theta_{\infty}) \cdot (e^{-kt_i} - e^{-k(t_i + \Delta t)}) = e^{-kt_i} \cdot (\theta_0 - \theta_{\infty}) \cdot (1 - e^{-k\Delta t})$$

then logarithmized:

$$\ln(\theta_{t_i} - \theta_{t_{i+1}}) = -kt_i + \ln((\theta_0 - \theta_\infty) \cdot (1 - e^{-k\Delta t})).$$

The logarithmic term to the right of the expression is constant if  $\Delta t$  is constant, i.e., we used the same time interval between the measurements. Thus, the calculated values of  $\ln(\theta_{t_i} - \theta_{t_{i+1}})$  plotted versus the time give a straight line. From the slope, the rate constant can be determined. This method does not require measuring either  $\theta_\infty$  or  $\theta_0$ , on the other hand, it requires that the rotation be measured at the same time intervals! The previous methods did not require that timing of the measurements.

5. **Nonlinear parameter estimation:** Eq. (1) can be used without any modification. The method requires more serious computing, but provides the greatest freedom. Nonlinear parameter estimation does not make any requirement to the timing of measurement points, several curves can be evaluated together and any of the values  $k$ ,  $\theta_\infty$  és  $\theta_0$  can be fitted or can have a fixed value.

## 2 The practice

In this practice, the rate constant of sugar inversion should be determined by the methods described above. The optical rotation of the solutions is measured with a polarimeter at a constant acid concentration. A description of the polarimeter and instructions for use can be found together with the equipments. For more information on setting the polarimeter and reading the rotation angle, see the Appendix.

### 2.1 Experimental, carrying out the measurements

1. If not available, prepare 200 cm<sup>3</sup> 6.0 M hydrochloric acid solution and 100 cm<sup>3</sup> sugar solution. The concentration of sugar is given by the instructor, in the range of 0.6–1.1 M (0.20–0.37 g/cm<sup>3</sup> mass concentration range).
2. To determine  $\theta_\infty$ , measure 20 cm<sup>3</sup> sugar solution and 20 cm<sup>3</sup> 6.0 M hydrochloric acid solution into a stoppered Erlenmeyer flask. After mixing, put aside, the rotation will have to be measured at the end of the practice when the reaction is complete (at least two hours).
3. To determine  $\theta_0$ , mix 20 cm<sup>3</sup> sugar solution with 20 cm<sup>3</sup> distilled water (no catalyst, practically no hydrolysis). With this solution, wash the cuvette of the polarimeter (in small portions, several times) and then fill the cuvette with the solution. (Preferably without bubbles, but if a bubble remains, trap it in the bulging part of the cuvette so that it is not in the light path. Make sure the cuvette windows are clean and dry.) Place the tube in the polarimeter cuvette holder and measure the angle of rotation of the light. Since the solution does not change, you have time to understand using the polarimeter. *Values measured in section 2 and 3 will be  $\theta_\infty$  and  $\theta_0$  in each measurement, since only saccharides are optically active, water and hydrochloric acid are not.*
4. According to the instructor's instructions, prepare 50 cm<sup>3</sup>, 2.0–3.0 M hydrochloric acid solution from the 6.0 M solution by dilution. Measure 20 cm<sup>3</sup> sugar solution and 20 cm<sup>3</sup> hydrochloric acid solution into two separate (dry) beakers. Start the stopwatch when the two solutions are mixed (homogenize the reaction mixture by pouring the solutions back and forth from the beakers). Wash the cuvette of the polarimeter (in small portions, several times) and then fill the cuvette with the solution. Place it in the cuvette holder of the polarimeter and measure the angle of rotation of the light as a function of time. To use the Guggenheim method, measurements should be performed every 2 minutes. The total time of the measurement is determined by the instructor (approx. 60 min).
5. As instructed, prepare a more concentrated hydrochloric acid solution from the 6.0 M solution by dilution. Repeat the previous measurement with the higher catalyst concentration. The total time of the measurement is determined by the instructor (approx. 30 min).
6. Measure  $\theta_\infty$  according to the previous procedures, using the solution prepared in step 2.

## 2.2 Evaluation of measurement results

1. Record the measured values of  $\theta_\infty$  and  $\theta_0$ .
2. The measured and calculated data should be summarized according to the table below:

t/min	$\theta_t/^\circ$	$\ln \frac{\theta_t - \theta_\infty}{\theta_0 - \theta_\infty}$	$\ln(\theta_t - \theta_\infty)$	$\ln(\theta_t - \theta_{t_1})$	$k = -\frac{1}{t} \ln \frac{\theta_t - \theta_\infty}{\theta_0 - \theta_\infty}$

3. Make the  $\theta_t - t$  plots for each measurement. They can be on the same figure.
4. Determine the pseudo-first-order rate constant of sugar inversion for both measurements applying the methods requested by the instructor (see Ch.1.2). In the relevant cases, fit the data sets in order to determine the parameters and their standard deviations (see Appendix). If needed ask the instructor's help to perform nonlinear parameter fitting (Excel Solver, QtiPlot, Origin).
5. Characterize the evaluation methods (which and when is more accurate, faster) by comparing the graphs ( $R^2$ ), the calculated k values and their standard deviations. Try to estimate the accuracy of the experiments.
6. Compare the values of the determined pseudo-first-order rate constants as a function of hydrochloric acid concentration.

### Control questions:

1. What reaction do you study at the practice?
2. What is plane polarized light, and how does a polarimeter work?
3. What is molar rotation? What is the specific rotation? How does the angle of light rotation depend on the concentration?
4. If you mix  $20\text{ cm}^3$  sucrose of  $250\text{ g/dm}^3$  mass concentration with  $20\text{ cm}^3$  water, what will be the light rotation of the solution at  $2\text{ dm}$  light path. The specific rotation of sucrose is  $66.5\text{ (}^\circ\text{ cm}^3\text{)/(g dm)}$ .
5. If the specific rotation of sucrose is  $66.5\text{ (}^\circ\text{ cm}^3\text{)/(g dm)}$ , what is its molar rotation?  $M_r(\text{sucrose}) = 342$
6. How to prepare  $100\text{ cm}^3$  of  $2.2\text{ M HCl}$  solution by diluting from a  $6\text{ M}$  stock solution?
7. What is the mass concentration (in  $\text{g/cm}^3$ ) of an  $0.5\text{ M}$  sucrose solution?  $M_r(\text{sucrose}) = 342$
8. Write the differential and integrated form of the rate equation for a first-order reaction.
9. Introduce the methods in 1 – 1 sentence which are applicable for the graphical determination of a first-order rate coefficient? (Equations are not necessary.)
10. What is the Guggenheim method for calculating rate coefficients? Derive the method of calculation.
11. Why is  $[\text{H}^+]$  not in the rate equation, even though the inversion rate depends on it?

## Appendix: Using the polarimeter

With manually adjusted polarimeters, the plane of polarization is difficult to determine because our eyes are not sensitive enough to determine either the maximum light intensity (same position of the optical axes of the polarizer and analyzer) or the minimum light intensity (crossed position). The eye is much better in comparing light intensities, so to help more accurately reading the plane of polarization or the angle of rotation, we do not use a single polarizer, but a polarizer system with a slightly different optical axis (difference  $1-2^\circ$ ).

Light polarized in two slightly different planes by two polarizers results in two different light intensities when viewed through the analyzer. At high intensities, this is not noticeable, so we prefer to use the crossed position. Find the position of the analyzer when the light from the two polarizers has exactly the same intensity, i.e., the analyzer has an optical axis perpendicular to  $\delta/2$  (Figs. 6 and 7).

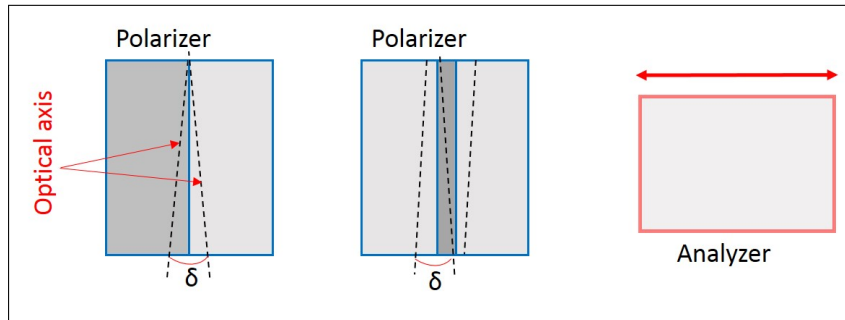

Figure 6: Possible variants of polarizer systems.

If the setting is good, read the analyzer's angular position. For a more accurate reading, we use the so-called Vernier scale. The scale rotating with the analyzer shows the polarization and / or the angle of rotation in degrees. The position of the 0 of the auxiliary scale (Vernier scale) shows which integer degrees the setting is between. The division of the auxiliary scale line, which coincides with one (any) line of the rotating scale is an estimate of the decimal degree. If we are below  $0^\circ$ , we have to read it in the same way, but these are already negative angles (the optical axis has turned  $180^\circ$ ), so subtracting  $180^\circ$  gives the correct angle. The  $9 \text{ main scale} = 10 \text{ Vernier scale}$  (see Fig. 8) is suitable for estimating  $0.1^\circ$ , the  $19 \text{ main scale} = 10 \text{ Vernier scale}$  is suitable for estimating  $0.05^\circ$ , the  $49 \text{ main scale} = 10 \text{ Vernier scale}$  can be used to estimate  $0.02^\circ$ . (By the way, this is how calipers and micrometers can be read!)



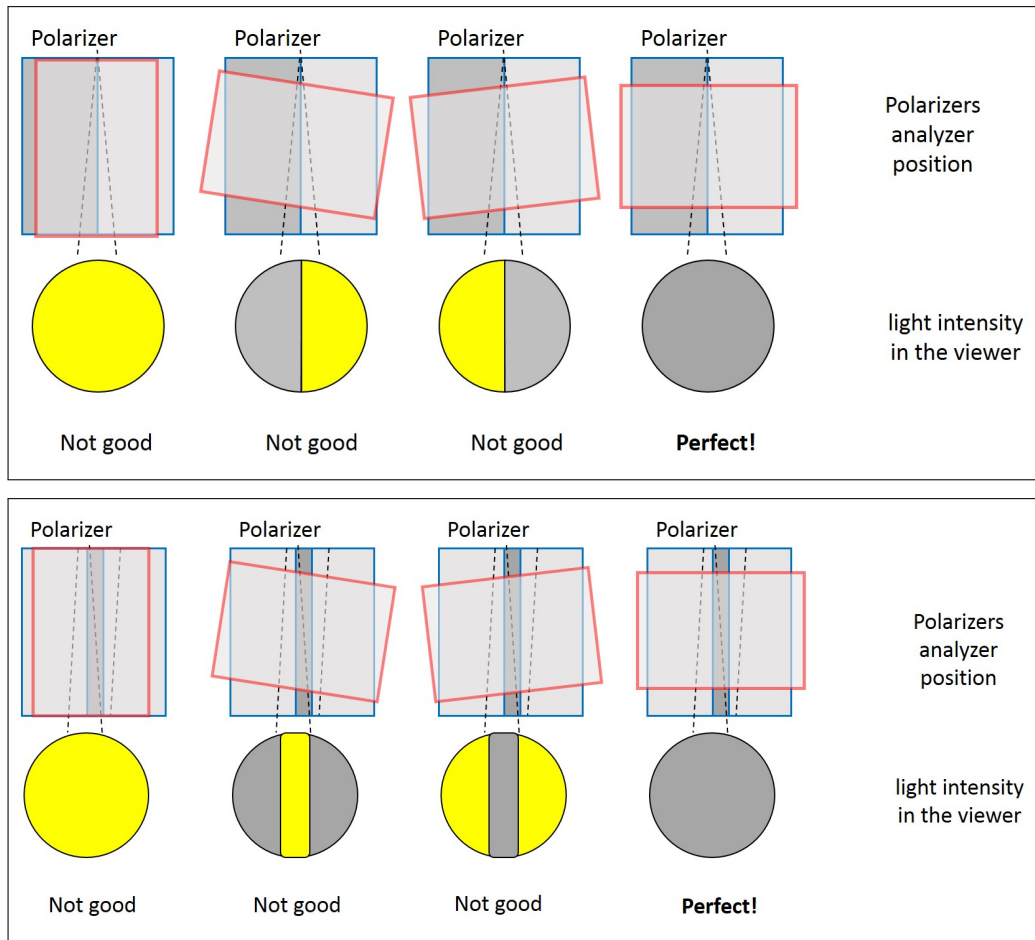

Figure 7: The relationship between the different angular positions of the analyzer and the intensity of the light passing through the polarizers for different types of polarimeters.

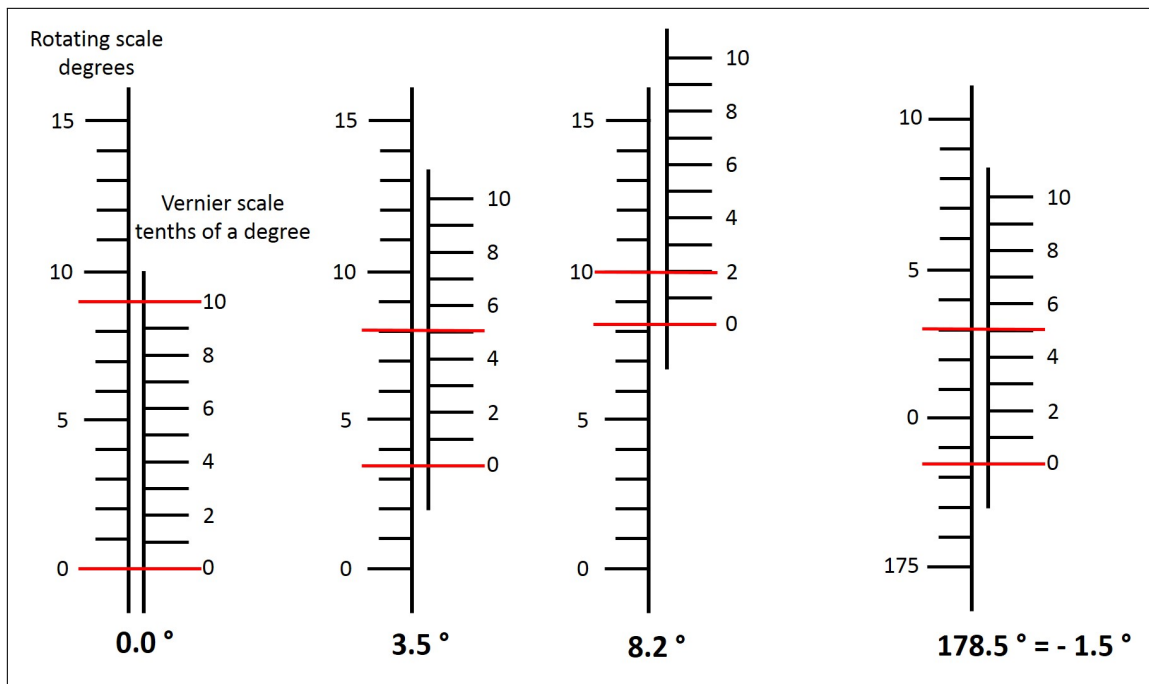

Figure 8: Using the Vernier scale.